

## MONTAGEMODUL FÜR DAE-MEMBRANE VOM NITTO-BAND

**ANWENDUNG:**  
 Verschweißen von Druckausgleichs-  
 elementen auf Kunststoffteilen

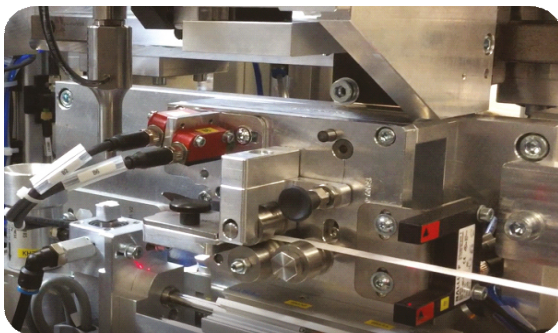
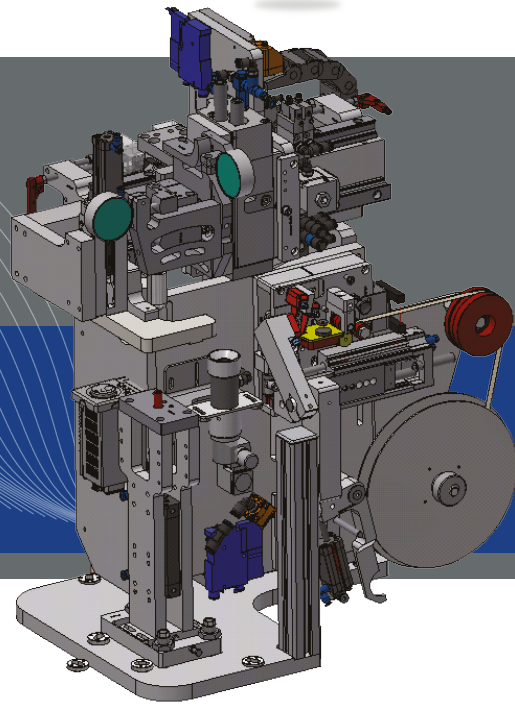

### PROZESSABLAUF

1. Bandzuführung Nitto-Band
2. Flexibler Zuschnitt Nitto-Einzel-Membran
3. Pick&Place Handling Einzel-Membran
4. Ultraschallschweißen der DAE-Membran in Kunststoffteil (35 kHz)

### VORTEILE

- o Enormes Kostenoptimierungspotential bzgl. Bandmaterial und Zuschnitt
- o Robuste und prozesssichere Lösung aus Baukastensystem
- o Einfache Integration in bestehende Systeme
- o Kompakte Bauweise bei hoher Präzision und Wiederholgenauigkeit
- o Kombinierbar mit Testsystemen aus unserem Hause



## ASSEMBLY MODUL FOR ePTFE-MEMBRANE FROM NITTO-TAPE

**APPLICATION:**  
ultrasonicwelding of ePTFE-  
membrane on plastic parts

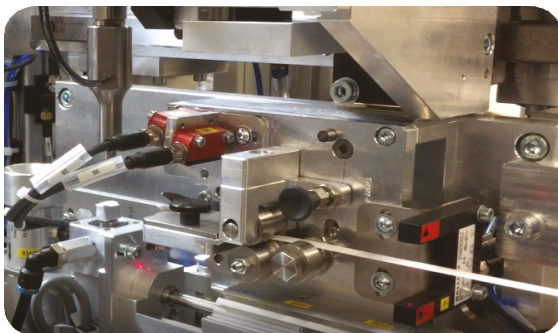
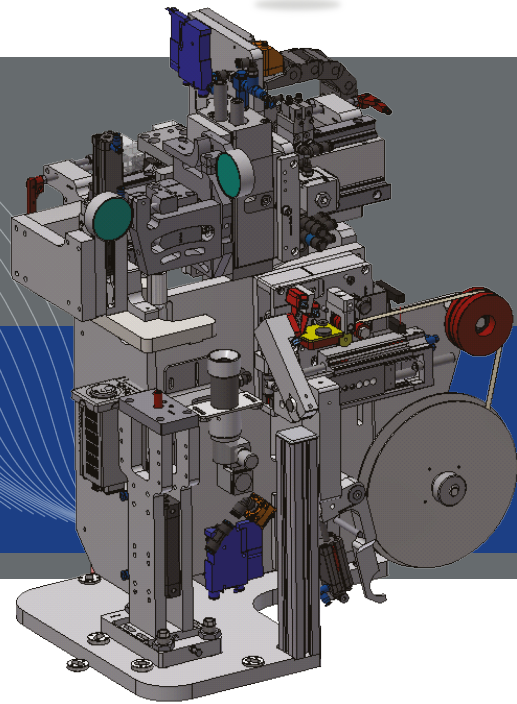

### PROCESS PROCEDURE

1. Feeding of Nitto-tape
2. Flexible cutting for Nitto-single-membrane
3. Pick&Place handling for single-membrane
4. Ultrasonicwelding of ePTFE-membrane on plastic parts (35 kHz)

### BENEFITS

- o Enormous cost-optimization potential with regard to strip material and cutting
- o Robust and process safe solution from modular system
- o Easy integration into existing systems
- o Compact design with high precision and repeatability
- o Can be combined with other ZWERRENZ test systems

